

Global Energy Management System Implementation: Case Study

Republic of Korea

LG Electronics Cheongju Plant

Since the introduction of the energy management system, we have achieved a 4% energy performance in 2016 (1 year) compared to 2015 as a result of quantitative evaluation.



Since its founding in 1985, the LG Electronics Cheongju Plant has been continuously developing and employing about 430 employees on a land area of 51,638 square meters

Business Case for Energy Management

LG Electronics has established an **EESH (Energy / Environment / Safety / Health) policy** * to implement environmental management under the vision of protecting the clean earth and human health.

* EESH Policy: The activities for optimize of energy efficiency, eco-friendly process operating and brand-new product developing, wealth & safety of workplace and health promotion for employees were conducted thereby implementing the Global Top Company in the EESH field and providing differentiated value to our customers, we seek to preserve the global environment and promote sustainable social development and enhance the quality of life for stakeholders.

“With the introduction of ISO 50001, we were able to gain confidence in investment decisions through clear cause analysis.”

Case Study Snapshot	
Industry	LG Electronics Cheongju plant
Product/Service	SRS
Location	Cheongju
Energy Management System	ISO 50001
Energy Performance Improvement Period	1
Energy Performance Improvement (%) over improvement period	4%
Total energy cost savings over improvement period	328,000 USD
Cost to implement EnMS (just for capital investment)	749,800 USD
Payback period (years) on EnMS implementation	2.3year
Total Energy Savings over improvement period	14,661(GJ)
Total CO ₂ -e emission reduction over improvement period	722



Fig. Environment Management

Under the vision of environmental management, to cope with climate change, LG Electronics has established four strategies: productivity improvement, product competitiveness improvement, operational efficiency improvement, and social contribution since 2009. In order to achieve this goal, we have set a detailed goal of reducing 150,000 tons of emissions by 2020 (10% of the base year) compared to 2008 emissions.

As part of the achievement of the goal, LG Electronics introduced the energy management system throughout the company, including the Cheongju plant, and received the initial certification in December 2010.

LG Electronics Cheongju plant is the electronic components & Material Division and comprised of three business segments: energy, water treatment, and display. Main products of the plant include SRS (Safety Reinforced Separator), Solar Cell paste, and security sheet.

LG Electronics Cheongju plant confirmed that energy use of utilities is high due to the nature of the business site and management of the energy is important in the introduction of the energy management system. We have invested in monitoring infrastructure to manage and analyze energy usage of the utilities. Through this, it was evident that the data, which could be estimated as an energy waste factor but could not have certainty, was able to clearly show the vitality of the project.

Through the confirmation of clear performance for energy efficiency improvement activities and improvement of the energy management system, we have established a virtuous cycle system that can continuously improve energy efficiency.

Business Benefits Achieved

Under the medium- and long-term goal of achieving a 10% reduction in greenhouse gas emissions by 2020 compared to 2008 emissions, LGE's Cheongju plant is undertaking company-wide efforts to reduce energy consumption by 3% every year.

Energy management systems have been helpful, directly or indirectly, to achieve energy objectives.

Under the management's interest and active support, the company has given each department a clear role, responsibility, and goal for energy management activities, which led to active participation.

Company-wide participation which is a top-down initiative of energy management activities that establish goals, targets and action plans in their respective roles and review and approve them by management has led to practically achievable energy management activities. As a result, we were able to derive significant energy performance as follows. These achievements are the results of the energy management activities carried out by the Korea Energy Corporation (KEPCO) as a result of the third-party verification.

- Baseline period : 2015
- Project period: 2016
- Energy performance (Electricity): 4.91 % (13,114 GJ)
- Energy performance (Steam) : 1.48 % (1,547 GJ)
- Energy performance (Total) : 3.94 % (14,661 GJ)
- Energy reduction costs : 328,000 USD/year

In order to achieve net profit of about 328,000 USD per year, it is necessary to sell over 328,000 USD of commodities. As a result, the value of cost savings through energy savings can be seen as a greater value than the nominal value, which will spur more energy savings.

EnMS Development and Implementation

It is indispensable to systematically manage, analyze and efficiently use energy due to internal and external factors such as LGE's EESH policy at the headquarters, enriched environmental regulations such as the energy greenhouse gas emission trading system, and strengthening consumer awareness of the environment. For systematic approach, LG Electronics Cheongju plant has also introduced an energy management system under the leadership of the head office and has achieved considerable achievements.

Organization

Under the overall support and active support of the EESH committee chairman of LG Electronics Cheongju plant, the Cheongju support team plays an overall role

in energy management as an energy management team. The main role is to continuously improve the energy management system for collection, management and analysis of energy use data and technical support for each team's energy saving activities.

Each production team is constantly striving to improve productivity with the belief that productivity improvement is energy saving and each support department also provides support and training to prevent energy wasted on its own and to use energy-efficient products.

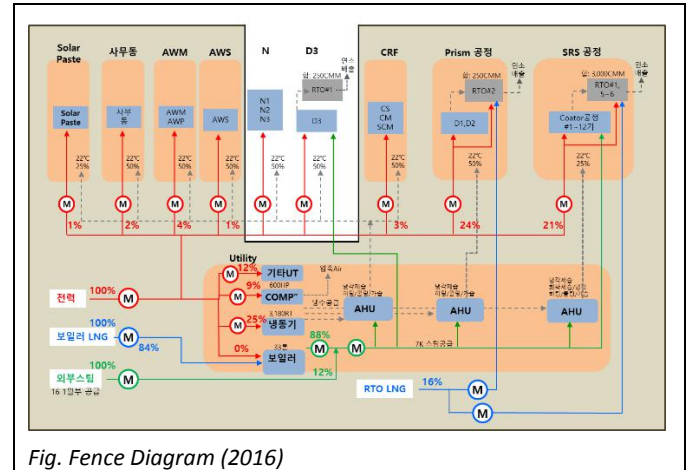

Fig. Fence Diagram (2016)

Identify changes in energy usage due to process and product changes and reflect these in the establishment of baselines and performance indicators.

Significant Energy Use (SEU) Drawing

The SEU that should be managed and analyzed and the reduction activity should be led through the grasp of the present situation.

SEU selected utility facilities that account for about 40% of total energy use and We have developed data-based improvement opportunities by providing a basis for managing the energy usage of refrigerator, air conditioning, and compressed air.

“The energy management system helped us to demonstrate our ability to select and focus on the enterprise”

Significant Energy Use (SEU) Drawing

The plant's energy management system at LG Electronics' Cheongju plant monitors real-time monitoring of energy usage for U / T, refrigeration, air conditioning, compressed air, and power systems and factors influencing (outdoor temperature, humidity, and production).

It was possible to identify their energy use, flow, and relationship through the overall system approach, not individual approaches such as air conditioning and

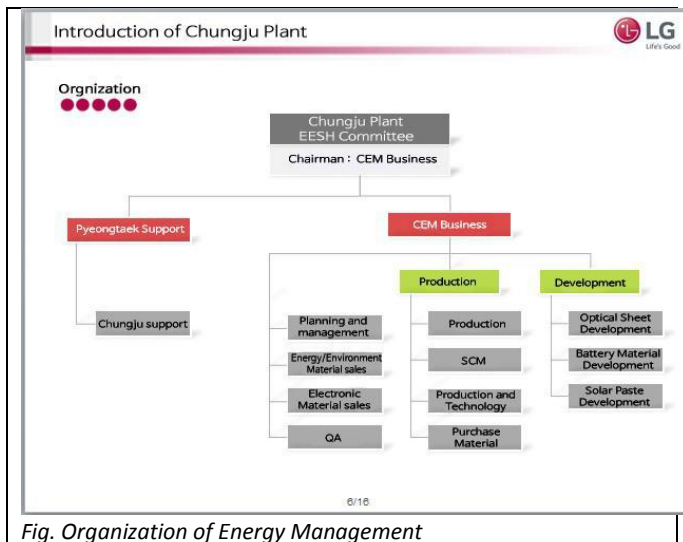

Fig. Organization of Energy Management

Energy review and planning

Understanding of the current situation

Due to the nature of the LG Electronics Cheongju plant, product and process changes frequently occur. The energy management team is updating the latest version of the Fence Diagram, which can identify the energy flow at a glance every year including the change.

freezers and this approach was able to identify opportunities for improvement.

In order to implement the improvement opportunities, the energy management system quantified based on the accumulated data, pointed out the problems, and confirmed the quantitative forecasting results to clarify the investment decision.

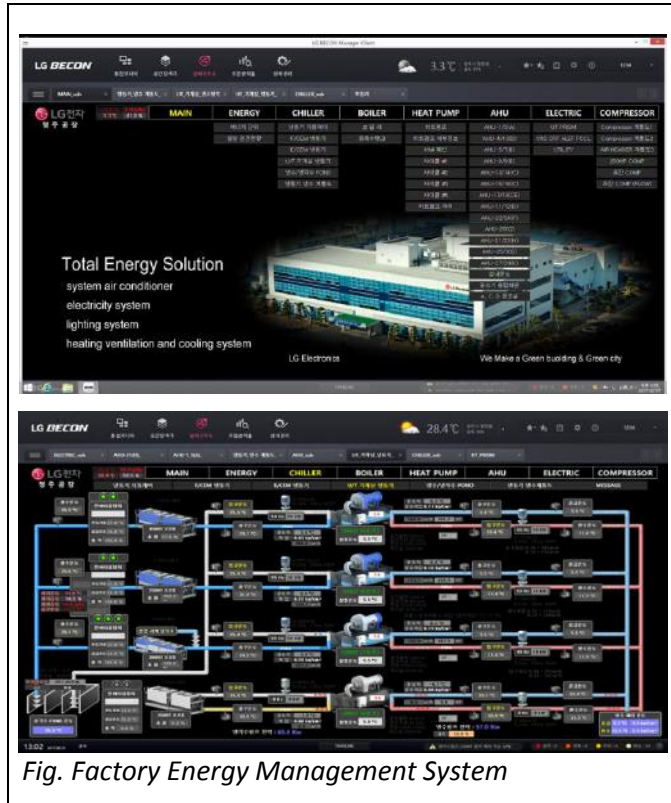

Fig. Factory Energy Management System

Energy Performance Check

Identifying of Influential factors

We predicted and analyzed the factors affecting each energy use and derived the factors affecting the energy use of LG Electronics' Chungju plant.

Table. Identifying of Influential factors

Energy Source	Independent Variable (P-Value)				F-Test	Adj. R ²
	Prism (m)	SRS (m)	제습 (4g)	HDD (22°C)		
Electricity (GJ)	0.0006	0.029	0.00		0.00	96.39%
Steam use (GJ)		0.045		0.00004	0.00	82.47%

Energy performance drawing

Using the derived influence factors, energy performance of 2016 compared to 2014 was verified and 5.44% of energy performance was confirmed.

Table. Energy Performance Drawing

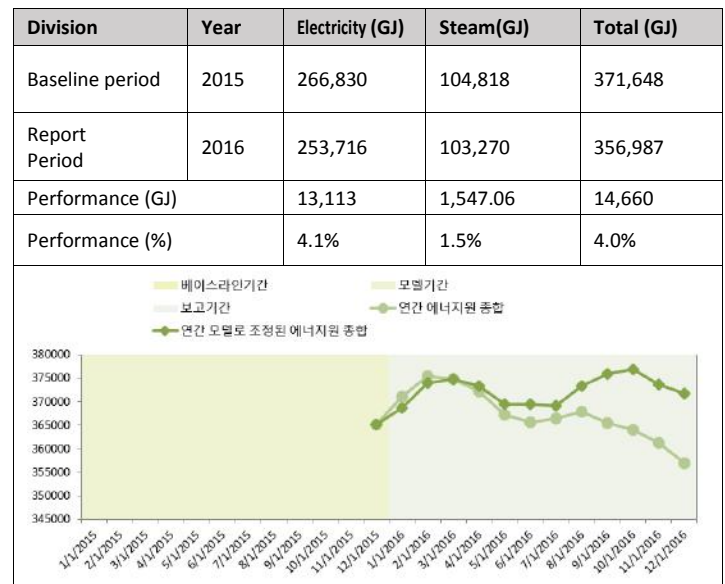

Cost Benefit

During the planning process, a variety of activities have been uncovered, from activities that do not require investment to activities that involve substantial investment, and many projects have been implemented through economic feasibility studies.

The production team worked on productivity improvement and operation optimization activities and improved the large cold water system to reduce utility power consumption.

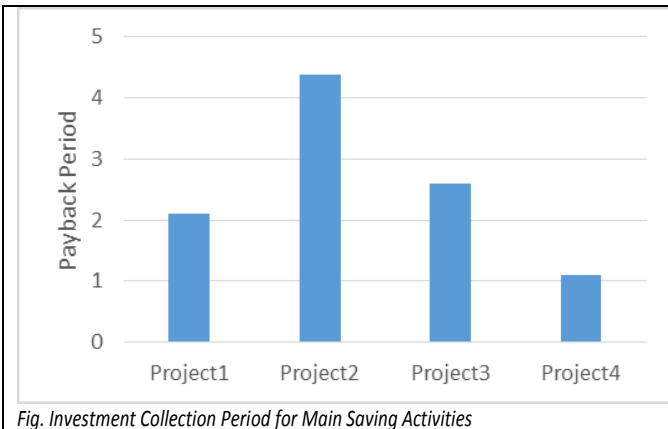

Through further research and analysis on the future methodology, we plan to upgrade the M & V system for LG Electronics' Cheongju business site. We plan to provide a basis for efficient analysis and management of these systems by reflecting these parts in the system.

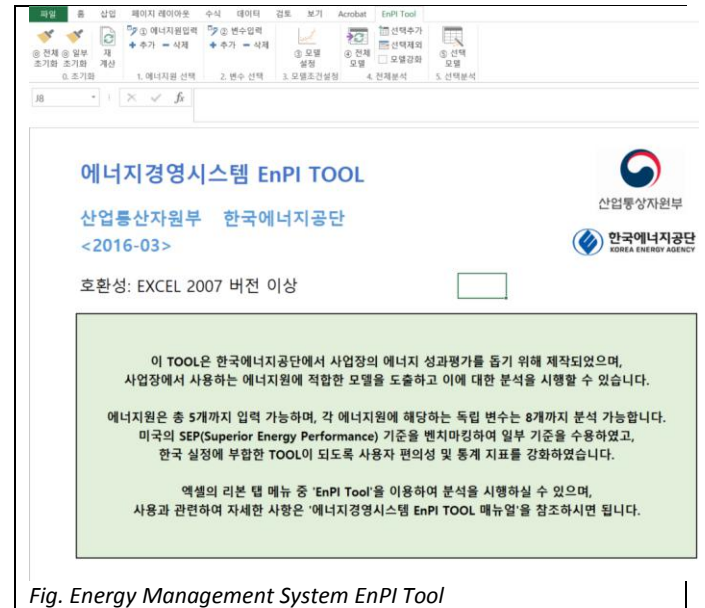

Through the implementation of such energy efficiency improvement activities, we confirmed the energy cost savings of about 328,000 USD during the achievement period (2016). The investment recovery period for saving activities, excluding internal manpower costs and EnMS certification and related investment costs, is about 2.3 years, and energy efficiency will be improved through aggressive investment.

Communication, Education and Tool

Provide information and analysis results on energy use by each department for the enterprise-wide participation in energy management, and communicate regularly to discuss energy management.

In addition, energy conservation campaigns, promotions, and education are actively engaging in energy conservation, motivating people to participate through ideas and rewards.

We have strengthened the M & V capabilities of practitioners by participating in the performance evaluation training conducted by the Korea Energy Corporation to apply and acquire advanced energy performance evaluation methodology using regression analysis presented in ISO standard and M & V literature.

We applied the M & V methodology and the energy management system EnPI Tool, acquired in education, to the energy management system at LG Electronics' Cheongju plant to derive the quantified results.

Lessons Learned

Establishment of data-based energy management system is important

There are many cases where we are hesitant to proceed because we are not sure about the energy efficiency improvement activities in the energy related work.

As a solution to this problem, we first determine the parts that need to be analyzed and then prepare and accumulate base data to analyze them, and provide data on the merit of performing energy efficiency improvement activities. Based on this, we were able to draw investment decisions effectively by diagnosing clear problems and deriving expected results.

Preparation of best practices

It is necessary to carry out the analysis from a small part through centralized construction of one part rather than the establishment of system through large-scale investment in the factory energy management system. It is important to identify the improvements through

these analyzes and make improvements, and then make sure that the best practices are identified through clear performance reviews.

Based on best practices, investing in infrastructures that can analyze a little more and expanding the existing system problems will be an effective energy management and analysis method.

LGE's Cheongju plant is making progressive investment in this approach and is making improvements to enable automatic control of utility facilities through learning.

Reducing energy costs leads to profit

Achieving the net profit that corresponds to the cost of energy savings requires several times more effort and costs, such as selling, marketing.

Energy-saving activities are not just wasted costs, but they are also very important activities to raise company's sales and improve cost competitiveness so it is necessary to strive with a sense of duty in activities to reduce energy.

Keys to Success

- Construction of energy management system
- Efficiency improvement activities based on data
- Sincere approach to energy management activities

Through the Energy Management Working Group (EMWG), government officials worldwide share best practices and leverage their collective knowledge and experience to create high-impact national programs that accelerate the use of energy management systems in industry and commercial buildings. The EMWG was launched in 2010 by the Clean Energy Ministerial (CEM) and International Partnership for Energy Efficiency Cooperation (IPEEC).

For more information, please visit www.cleanenergyministerial.org/energymanagement.

